

Bondstrand®

Guide for Installing Buried Pipe

Introduction

To ensure long life and trouble-free service from a piping system, proper application of the essential principles of excavation, laying and jointing, bedding backfilling and field testing is required. If pipe is installed by a contractor it is equally essential that these principles be reflected in the phrasing of contract documents and that the customer enforce them through its inspection. The recommended practices presented in this guide for the installation of buried Bondstrand pipe are developed from the two basic concepts outlined below. Both should be rigorously maintained to obtain best results.

First, the manufacturer's recommendations for assembling pipe sections and curing the joints should be carefully followed. Second, each section of pipe should have its support well distributed under the pipe rather than concentrated at points or along a narrow portion of the pipe bottom. This is accomplished by providing proper bedding.

These instructions are intended to be used as a guide and should be amended of a specific job. Because any specification should be properly administered and expanded to meet the requirements enforced, there is no assurance-specific or implied-that inclusion of these paragraphs in a specification will insure a successful job; however, they should assist materially in accomplishing this objective.

1. Receiving, Storing and Handling of Pipe

1.1 Inspect incoming shipments of Bondstrand pipe and fittings for abuse in shipping. Broken pipe bundles, crushed fittings boxes, scratched and gouged pipe and pipe with crushed or split ends are evidence of such abuse. If abuse is and pipe with crushed or split ends are evident, damage claims procedures must

be initiated prior to accepting the shipment. Under shipping procedure, title passes at the time of shipment.

1.2 Do not throw or drop pipe and fittings-protect from all types of impact. Bondstrand may be damaged by careless handling, sometimes without exhibiting visible effects on the pipe surface.

1.3 Pipe or pipe bundles may be stored for extended periods in stacks up to 4 foot high. The sides must be stabilized to prevent slumping. A leveled, soft earth surface free of rocks and other hard or sharp objects is recommended. If stored in racks or on bearing boards, the supports should be at least 3 inches wide and smooth or cushioned. The supports should be placed at two locations approximately 4 or 5 foot from each end for 20-foot lengths. For 40-foot lengths, 4 supports should be used with two of them placed approximately 4 or 5 feet from each end and the other two placed at 10-foot intervals to support the middle of the pipe.

1.4 Follow normal procedures for stringing pipe along work site, placing pipe where it will be protected from traffic and impact.

1.5 Pipe supplied in 20-foot lengths should be lifted and carried at the center by hand or using webbed straps or rope. If handled at the ends, avoid touching and contaminating the joining surfaces.

1.6 Pipe supplied in 40-foot lengths should be lifted (and carried) at two points about 10 feet from each end. Use rope or web slings for mechanically lifting the pipe. Weight of 40-foot lengths are

Diameter (in.)	Weight (40 ft length) lb
4	75
6	120
10	215
8	170
12	250

1.7 For work on the pipe, such as cutting, preparing ends, or cleaning, two-point support is recommended for 20-foot lengths, and three-point support for 40-foot lengths.

Note: Do not place supports under bells, spigots or factory-made joints.

2. Assembly of Pipe and Fittings

2.1 Prepare and assemble Bondstrand Quick-Lock® joints in accordance with the Bondstrand Assembly Instructions, using special care to keep joint surfaces clean and dry.

Note: Be sure all pipe assemblers are thoroughly trained in Bondstrand assembly procedures, and recognize the importance of using proper techniques.

2.2 Position pipe on timbers across ditch as shown in figure below. Block into position to hold alignment and prevent lateral movement. For larger diameters the use of a winch is recommended to assemble and hold joint as illustrated in Bondstrand Assembly Instructions

Positioning Pipe Over Ditch

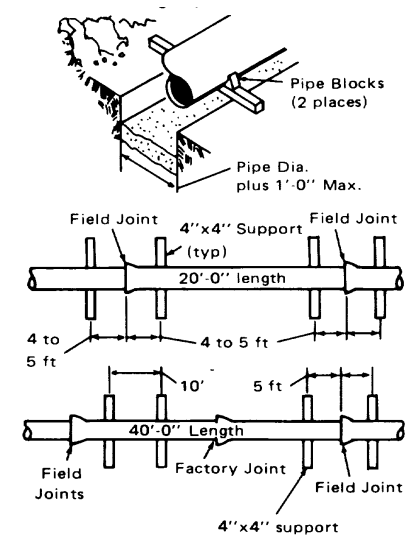

3. Placing Pipe in Ditch

3.1 Join the pipe sufficiently in advance of the pipe lowering operation so that no movement of the pipe will take place at location where joints are being cured. Any vibration or movement of uncured or partially cured joints will increase the risk of joint failures

3.2 With power equipment or manpower, raise the pipe slightly to slide the timber support from under the pipe. Lower the pipe into the ditch. Do not drop or lower suddenly (see fig. below). Repeat the above operation at each support Use

rope or webbed sling for lifting pipe. If manpower is used, it is suggested that two men be used for lifting and lowering 6-inch pipe, and four men be used for the 8-inch and 10-inch pipe.



3.3 Should the depth of the trench measured from the top of the supports upon which the pipe is assembled to the trench bottom exceed 5 feet, do not lower the pipe into the trench by the method outlined in 3.2 as it may overstress the pipe. It shall be the customer's responsibility to submit specific laying conditions (trench depth, handling equipment, pipe diameter, etc.) to Ameron for an evaluation and recommendation for trench depths in excess of 5 feet.

3.4 Pipe may be placed in the ditch on a curved alignment provided the curvature in the installed pipe is uniform and does not exceed the following:

Pipe Diameter (in.)	Mid-Ordinate to 100-ft Chord Length (ft)	Bending Radius (ft)
2	16.5	84
3	10.5	124
4	8.1	159
6	5.3	235
8	4.1	305
10	3.2	381
12	2.7	451

Curvature may be vertical, horizontal, or a combination of these. Restraints, if required for alignment control, shall each bear along a minimum of 4 inches of pipe surface

Curvature Control Terminology

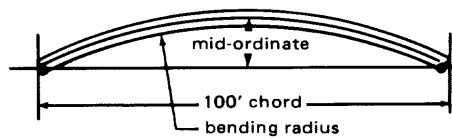

4 Bedding and Backfill

4.1 Bedding in the pipe zone should be sand and must not include rocks larger than 3/8 inches or sharp rocks of any size in direct contact with the pipe wall. Sand bedding under the pipe should be a minimum of 2 inches in thickness. Sand shall pass a 3/8-inch screen and not more than 15% shall pass a No.200 sieve.

4.2 Accurately grade the trench bottom and sand bed to provide uniform bearing and support for each section of pipe along its entire length. (This will require a shallow depression for bells and couplings.) The grade shall have no abrupt changes in direction or slope except at fittings.

4.3 Do not cover the pipe joints until all required pressure tests are performed.

4.4 Sand shall be uniformly compacted around the pipe with particular care given to the bedding beneath the haunches of the pipe. Sand may be densified by hydraulic methods if the native soil in which the trench is excavated is free draining. If trench is not free draining, placement of damp sand will facilitate compaction. Sand bedding and backfill should extend a minimum of 6 inches above the pipe.

Note: Filling the pipeline with water or other means shall be used to prevent

"flotation" of the buried pipe if hydraulic methods of consolidation are used in cohesionless soils.

4.5 Backfill shall be deposited in 6-inch maximum layers to a point at least two feet above the top of the pipe, each layer being compacted with suitable tampers to 85% of maximum density as determined

in accordance with ASTM DI 557 for cohesive soils, or to 70% relative density in accordance with ASTM D2049 for cohesionless soils which fail to produce a well-defined, moisture-density relationship when tested in accordance with ASIM DI 557. Compacting shall be done so as to avoid damage to pipe wall. Remainder of backfill shall be placed as directed by the engineer.

In place tests of soil density are made in accordance with ASTM DI 556 or ASTM D2167

Note Mechanical compactors may be used provided harmful shock loads are not transmitted to the pipe. Maintaining a space of at least one foot between tamping feet and pipe wall should avoid damage to the pipe wall.

4.6 Where live load conditions do not exceed the conventional H20-S16 loading, minimum depth of burial measured from top of pipe should be three (3) feet for all diameters. At road crossings where the loading exceeds H20-S16, the pipe must be buried deeper, or consideration must be given to the use of a casing pipe. If casing is required, the use of collars or sleeves is suggested to provide protection for the pipe exterior. The pipe manufacturer will supply data on increased depth of burial upon request provided complete loading and soil conditions are submitted by the customer for an engineering analysis.

5 Thrusts

5.1 Evaluation of the need for thrust blocks is the responsibility of the engineering agency designing the system. Decision will depend on the exposure to temperature change, surges of internal pressure and geometry of the pipeline layout. For each of these factors, singly or in combination, the effect of movement and thrusts on the pipe joints and fittings must be evaluated.

(Additional information is found in Bondstrand Engineering Guides.)

5.2 Temperature changes produce stress in buried pipe which is restrained by friction of the surrounding bedding, by passive soil pressures at fittings, or by thrust blocks. Forces developed at fittings in fully restrained pipe are tabulated below.

Thrust in Pounds-Force at Fittings Due to 140°F Temperature Change in Epoxy Pipe

Nom. Dia. (in.)	At Tees or Ends		
	90° Elbows	45° Elbows	
2	1,880	2,660	1,440
3	2,830	4,000	2,170
4	4,550	6,430	3,480
6	6,760	9,560	5,170
8	9,710	13,700	7,430
10	12,200	17,300	9,340
12	14,500	20,500	11,100

Initial temperature = 60° F; operating temperature = 200°F

5.3 Hydrostatic thrusts at fittings depend on the degree of restraint on the pipe bonded to those fittings. In a fully restrained pipe (blocked against movement at both ends) with all joints bonded, the Poisson effect produces considerable tension in the pipe wall; that is, as internal pressure is applied, the pipe expands circumferentially and at the same time tries to shorten longitudinally. This tensile force in the Bondstrand pipe wall acts to reduce by about 50 percent the hydrostatic thrust on a fitting. Hydrostatic thrusts at fittings in fully restrained systems may be obtained for 100 psi pressure from the following table and determined for other pressures by proportion.

Hydrostatic Thrust in Pounds-Force at Bondstrand Fittings Caused by 100 psi Pressure in a Fully Restrained System

Nom. Dia. (in.)	Tee	Elbow		
		90°	45°	Lateral
2	170	245	130	170
3	405	575	310	405
4	675	950	515	675
6	1550	2200	1200	1550
8	2650	3750	2050	2650
10	4200	5950	3200	4200
12	6000	8450	4600	6000

Reducers			
3x2	235	8x 6	1100
4 x 2	505	10 x 6	2650
4 x 3	270	10x 8	1550
6 x 3	1150	12 x 8	3350
6 x 4	875	12 x 10	1800
8 x 4	1975		

5.4 Valves should normally be blocked as indicated in 6.8 to support their weight, resist their thrust and to prevent excessive loads on the pipe connections because of applied torque

5.5 Thrust blocks are required at hydrants and at 6-inch or larger diameter tees and elbows for fire water mains regulated by Factory Mutual Insurance

6. Thrust Blocks-Design and Construction

6.1 Once the applied thrusts are determined, the designer of thrust blocks must consider soil strength, soil stability and location of the water table. Blocks must have (1) adequate bearing area to resist the soil thrust, (2) bearing surface against undisturbed soil and (3) the resultant thrust vector passing perpendicularly through the center of the bearing surface (except for valves as in 6.8). Should the soil be unstable or the installation below the water table, the engineer will have to make special provision to ensure stability.

It is important to note that any connecting metallic pipe must be anchored at the point of connection to the RTR pipe to prevent excessive stresses being transferred to the RTR pipe.

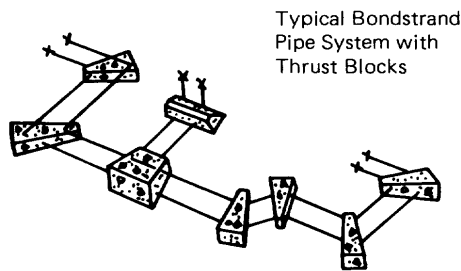

6.2 Safe bearing pressures for several soil conditions are as follows:

Safe Bearing Pressure of Soils

Soil	Sp Safe Bearing (lbs/ft ²)
Rock, hard thick layers	400,000
Rock, equal to good masonry	50,000
Rock, equal to best brick	30,000
Rock, equal to poor brick	10,000
Clay, always dry	8,000
Clay, fairly dry	4,000
Clay, soft	2,000
Gravel, coarse sand, firm	16,000
Sand, compact, firm	8,000
Sand, clean, dry	4,000
Quicksand, alluvial soil*	--

*Piles or tie rods may be required in loose or soft soils, particularly when below the water table.

6.3 Bearing area required is computed using the formula

$$A_t = \frac{R}{S_p} \text{ Where:}$$

A_t = Bearing area of thrust block in square foot

R = Reaction in pounds

S_p = Allowable soil bearing pressure in Pounds per square feet

6.4 Thrust blocks for Bondstrand pipe systems should be poured after hydrostatic testing of the pipe. This will allow for clear visual inspection of all fitting joints during the test. To retain pipe in proper alignment while testing, the placement of sand bedding and backfill per 4.4 may be required. Joints may be left exposed for observation during test.

6.5 Thrust blocks should be shaped with the "designed bearing area" against virgin earth of the trench wall.

Smaller blocks using a dry mix may be shaped by hands but larger blocks (2 square feet or greater) will require forms

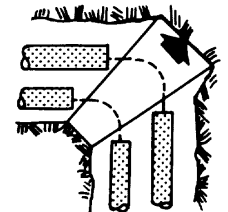

The trench should be undercut beneath the pipes at least 6 inches to give additional thrust resistance and to provide for an adequate concrete envelope around the fittings. At least 6 inches of concrete should be over the top of the pipe.

The center of the thrust block should coincide with the horizontal centerline of the pipe

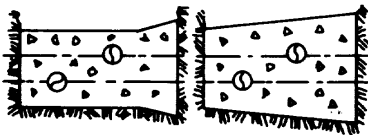

6.6 Unless otherwise specified by the engineer, an acceptable concrete is 1 part Portland cement 2 parts washed sand and 3-parts washed gravel with enough water for a relatively dry mix. The dry mix is easier to shape and offers higher strength

6.7 It is important that the concrete be **"worked" thoroughly around the elbows** for maximum surface contact. Take care that entire area between the fittings and the freshly cut trench wall is filled with concrete and free of voids.

Maintain at least a 2-inch space between concrete vibrators and pipe or fittings while compacting concrete. Even indirect contact through concrete aggregate may deliver excessive impact loads; this must be avoided.

6.8 Valve blocks should be poured under valves with the necessary steel that can be connected to the valve. This supports the weight of the valve and resists any torque or twisting action caused by opening and closing of the valve.

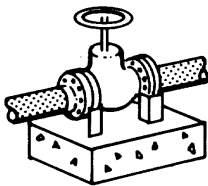

6.9 Thrust blocks for a crossover should be poured so that the crossover is encapsulated.

Thrust Blocking and Anchoring at Crossover

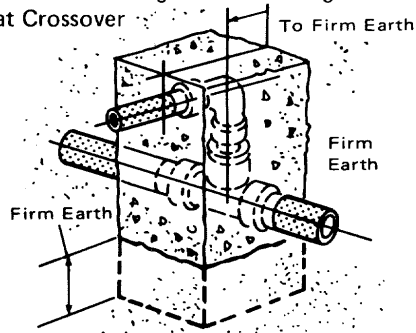

7. Manhole Penetrations and Connections

7.1 Bondstrand piping shall be laid in unless the drawings indicate otherwise. When Bondstrand pipe extends through a concrete wall, it shall be fitted into a metal pipe sleeve a minimum of two inches larger in diameter than the Bondstrand pipe size. The opening between the metal pipe sleeve and the Bondstrand shall be caulked with a waterproof compound which will dry to a firm but pliable mass

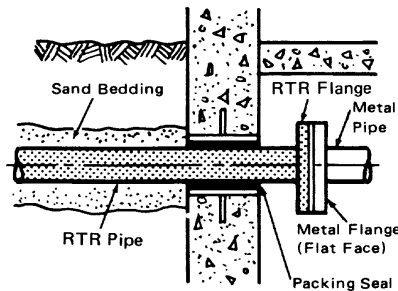

7.2 Flange connections shall be assembled in accordance with Bondstrand Flange Assembly Instructions.

7.3 When connecting Bondstrand to a metal piping system, anchor metal line to avoid stress transfer to Bondstrand.

7.4 Support valves independently of the pipe

8. Field Tests-Using Fluids

8.1 Pneumatic tests are not recom-

8.2 All free air in the Bondstrand pipe must be replaced by the test fluid. Provide taps for air and vapor removal at all high points in the system.

Important notice

This literature and the information and such a manner as to bypass manholes recommendations it contains are based on data reasonably believed to **be reliable. However, such factors as** variations in environment, application or installation, changes in operating procedures, or extrapolation of data may cause different results. Ameron makes no representation or warranty, express or implied, including warranties of merchantability or fitness for purpose, as to the accuracy, adequacy or completeness of the recommendations or information contained herein. Ameron assumes no liability whatsoever in connection this literature or the information or recommendations it contains.

Written comments regarding this document are invited. Please write Engineering Manager, Ameron Fiberglass Pipe Division.



Fiberglass Pipe Group Headquarters
P.O. Box 801148
Houston, TX 77280
U.S.A.
Phone: (+1) 713 690 7777
Fax: (+1) 713 690 2842
Internet: www.ameron-intl.com

Fiberglass Pipe Division The Americas
P.O. Box 878
Burkburnett, TX 76364
U.S.A.
Phone: (+1) 940 569 1471
Fax: (+1) 940 569 2764

Fiberglass Pipe Division Europe
Ameron B.V.
RO. Box 6
4190 CA Geldermalsen
The Netherlands
Phone: (+31) 345 587 587
Fax: (+31) 345 587 561

Fiberglass Pipe Division Asia
Ameron (Pte) Ltd
No. 7A, Tuas Avenue 3
Jurong
Singapore 639407
Phone: (+65) 861 6118
Fax: (+65) 862 1302/861-7834

